

What An Event!

Minnesota Green Expo 2003 • Minneapolis Convention Center

The first Minnesota Green Expo was held this past January at the Minneapolis Convention Center. As most are aware, this was a combined effort of your Minnesota Turf & Grounds Foundation and the Minnesota Nursery and Landscape Association.

The MTGF and the MNLA had held discussions for several years investigating the feasibility of hosting a combined educational and trade show event. Following extensive negotiations the contract was signed outlining the respective areas of responsibility and the general structure for the conduct of this event.

One of the biggest unknowns, as it is with all new ventures, was just how this effort would be received by

the various industries represented by MTGF and MNLA. As results show, the answer was nearly unanimously positive. 7,128 people registered as attendees and 376 exhibitors displayed their goods and services by contracting for over 750 exhibit spaces filling two domes of the Convention Center.

Separate post-conference surveys requesting evaluation of the Expo were sent to attendees and exhibitors. The responses received were extremely positive with very few exceptions. The issues mentioned in the exceptions have been evaluated and meetings have been held addressing those issues for next year's Expo where possible success in future years.

GREEN EXPO continued on page 4

2003 EXPO WINNERS!

Following the Minnesota Green Expo, two fax-back surveys were conducted – one for exhibitors and one of attendees. Approximately 350 surveys were returned. The information collected is proving extremely valuable as planning begins for the 2004 Minnesota Green Expo. Thanks to everyone who returned a survey. All those who returned surveys were entered in a drawing for a \$100 cash prize. The attendee name drawn was Douglas Blackmore of Northern Lights Landscaping in Duluth. The exhibitor name drawn was Mike McGregor of Isanti County Equipment of Isanti. Congratulations!



President Greg Hubbard presenting a plaque to long-time MTGF Board Member Mike Zins who has retired from the Board and the University of Minnesota.

TAKE A LOOK INSIDE

Field Day 2003.....	2
ED's Notes.....	5
Fertilizer Program	10
MSTMA News.....	12
President's Report.....	13
MAC Greetings.....	15

U. of M. Field Day

July 24, 2003 St. Paul Campus

7:45 A.M. – 1:00 P.M.

The fourth Annual University of Minnesota Turf and Grounds Field Day will be held on July 24, 2003. The University of Minnesota's faculty and staff involved with various turf and grounds teaching, research and outreach activities, in conjunction with the Minnesota Turf & Grounds Foundation are preparing for professionals in all phases of the Green Industry to visit the St. Paul Campus to see the results of their efforts.

An added feature this year is a phosphorus training program for golf course personnel offered immediately following the conclusion of the Field Day. Additional information regarding this offering is provided in a separate article in this publication.

All registration for the Field Day will again take place at the Trial and Display Garden location at the corner of Gortner and Folwell Avenues. Free parking off of Gortner Avenue immediately adjacent to the registration area will be available the same as last year. Signs will be posted to direct attendees to the proper areas. Coffee and pastries will again be available while supply lasts at no charge. A complimentary lunch will also be available during the event.

This year the majority of the turf portion of the Field Day will take place at the new TROE Center location. Since last year's Field Day a number of things have been accomplished that will be of interest to everyone involved in the industry. Following up on the success of last year, a second track is again offered that will focus on the "grounds" portion of the attendees.

The turfgrass track will cover a broad range of topics including turfgrass breeding, foliar feeding, soils, nutrient fate, ornamental grasses, insect and disease management and new technologies. **Dr. Brian Horgan, Troy Carson and Jon Sass** will conduct a tour of the TROE Center and address a variety of topics. Presentations will include nitrogen leaching and gas emissions from a USGA putting green, building a runoff facility, the use of soil moisture sensors to conserve water when irrigating and the Kentucky bluegrass NTEP evaluations. All of these topics can have a major impact on current and future activities in the area of turfgrass management. Environmental impact, water conservation and improvements in turf varieties all play a role in efforts to provide quality turf areas in an environmentally sound manner.

Dr. Nancy Ehlke will address breeding of new Kentucky bluegrass varieties as well as the selection process for improved winter hardiness of perennial ryegrass. Dr. Ehlke's work with Kentucky bluegrass employs mutation breeding through the development of a successful tissue culture program. Initial results indicate that there are progeny from regenerated plants that appear to have a higher level of disease resistance and improved turf quality including better color, leaf texture and growth habit from the original parental material. This is work that has been on going for a number of years and is showing promise for new varieties that will be entered in the 2005 NTEP trials with a potential release date of 2007.

In addition, efforts are underway to increase the winter hardiness and herbicide tolerance of turf-type perennial ryegrass. Following the evaluation of crosses using materials that demonstrate improved winter hardiness and turf quality, there are two populations with superior winter hardiness that are currently being released by the University of Minnesota and seed should be commercially available to turf managers in 2004 or 2005.

Research is also focused on using traditional plant breeding methods to develop herbicide tolerant perennial ryegrass using a naturally occurring, herbicide tolerant gene. The first herbicide tolerant perennial ryegrass was released by the University of Minnesota in 2001 and is called P101. Commercial seed production was initiated in northern Minnesota with seed potentially being available from production this fall. Additional work with perennial ryegrass includes the development of potential new cultivars with a spreading growth habit for improved wear tolerance and the incorporation of resistance to gray leaf spot which is a devastating new disease of perennial ryegrass.

Developing cultivars with genetically superior characteristics is an effort that will not only assist the turf manager but will provide the Northern Minnesota Forage and Turf Seed Advisory Committee, one of the Allied Associations of the MTGF, with additional options for crop production throughout northern Minnesota.

FIELD DAY continued on page 3

MTGF Allied Associations

Minnesota Association of Cemeteries

Minnesota Park Supervisors Association

Minnesota Sports Turf Managers Association

Minnesota Turf Association

Minnesota Golf Course Superintendents Association

Minnesota Society of Aboriculture

Minnesota Association of School Maintenance Supervisors

Northern Minnesota Forage and Turf Seed Advisory Committee

FIELD DAY *continued from Page 2*

Have disease problems? Still recovering from an "interesting" 2002? **Dr. Janna Beckerman** will be on hand to discuss turf disease issues and what might be in store for the coming growing season. Following one of the most challenging years for turf diseases in recent memory, Dr. Beckerman will discuss what might be in store for 2003 and what to look out for. Will turf weakened because of disease pressure last year be vulnerable to further damage in 2003? Attend this year's Field Day and "ask the expert"!

Dr. Carl Rosen &/or Dr. Peter Bierman are planning to conduct a demonstration on "evaluation of foliar iron formulations on turf quality". This is one more tool in the arsenal of providing quality turf for a variety of applications. Given budget and environmental concerns for maintaining our turf areas increasing at all levels, this demonstration may provide maintenance alternatives that would be practical for many attendees.

Dr. Vera Krischik, Entomology, will be presenting timely information on turf insect management that will address concerns with white grub management as well as Japanese beetle issues. This is an area that is receiving increased attention due to both real and potential damage occurring on many turf applications. Dr. Krischik will provide updated information that can be used by all turf managers in the coming season.

Brad Pedersen will again assist with the **grounds** portion of the Field Day. Brad has indicated that the Department of Horticultural Science Display and Trial Garden will be looking great this year and he and his people will be conducting tours of the many trial varieties that are being tested and displayed. In addition, this year there will be special signage that will allow for self-guided tours plus he will host a live question and answer session up in the Landscape Design Studio in Alderman Hall.

The annual Field Day is hosted to inform industry personnel of the latest research activities of the University faculty and staff currently working in the turf and grounds areas. We are offering our vendor members the opportunity to help sponsor refreshments and lunch again this year. All sponsors will be recognized prominently so that attendees are aware of those who support their activities in the turf and grounds industries. A separate mailing will be made offering this opportunity. However, if you prefer, please feel free to respond to this opportunity using the address information listed on this page for attendees.

The Field Day will begin with registration at the Department of Horticultural Science Display and Trial Gardens from 7:45 a.m. to 8:45 a.m. and end following lunch at noon. A separate registration mailing will be made in the near future. However, if you wish to "beat the rush", please use the registration form on this page.

Advance registration again is \$15.00 and will assist us with ordering refreshments and lunches. On-site registration will be \$20.00 and we will do our best to have enough lunches for those registrations also. However, because of advance ordering requirements, lunch cannot be guaranteed for on-site registrants. ■

UNIVERSITY OF MINNESOTA
MINNESOTA TURF AND GROUNDS
FOUNDATION FIELD DAY
JULY 24, 2003, 7:45 A.M – 1:00 P.M.
PRE-REGISTRATION FORM

Name: _____

Affiliation: _____

City: _____

State: _____ Zip Code: _____

Phone: _____ E-mail: _____

Pre-Registration for the 2003 Field Day,
per person \$15.00

Please indicate your preference.
_____ Turf Tour _____ Grounds Tour

Make checks payable and return to:
MTGF
University of Minnesota
422 Alderman Hall
1970 Folwell Avenue
St. Paul, MN 55108

*** After July 15 on-site registration fee
of \$20.00 per person applies.

GREEN EXPO *continued from Page 1*

Everyone involved realizes that improvements can be made and plans addressing those improvements are well underway for the 2004 Expo.

Speakers from around the country presented timely information on a wide variety of topics. Exhibitors displayed virtually as with any business endeavor, a financial model was developed for the initial Expo in 2003. Due to the enthusiastic response of attendees and exhibitors, this financial model was exceeded. The Boards of Directors of the principals of the Expo have met and have indicated their intent to build on this initial everything that is currently available in the Green Industry that would assist members in their efforts to provide quality turf and grounds areas under their responsibility. A number of non-profits were given the opportunity to publicize their offerings to attendees at no charge. The University of Minnesota put forth a massive effort to design, build and



Dr. Brian Horgan, University of Minnesota Turfgrass Extension Specialist, presents valuable information to turfgrass professionals attending the 2003 Expo.

man a huge display that filled an entire lobby entry area going into the trade show floor. There is a variety of photographs in this issue that show some of the highlights mentioned above. ■

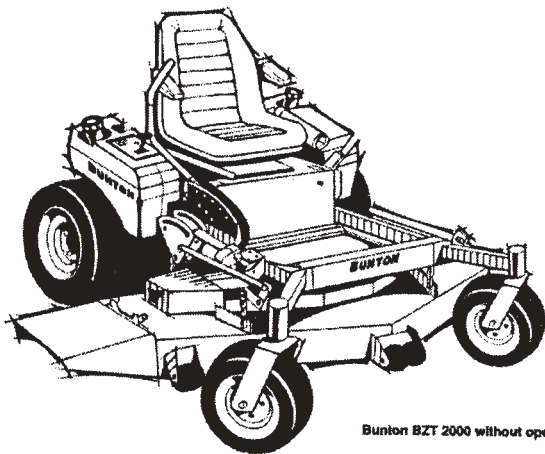

Buntion BZT 2000 without operator

From start to finish, the single source for all your turf care equipment and supplies is Sun Turf.



Turf's up! Ready to GO!

We're up and ready for another growing season. Proven turfseed mixtures and blends, top straight varieties, wildflower blends, fertilizer, erosion control products. And, "just right" prices and service. *Call today and watch us move.*

Celebrating our 10th Anniversary



TWIN CITY SEED COMPANY



ED'S NOTES

Larry G. Vetter
Executive Director

What a difference a year can make! Since this time last year, many things have happened that impact us all, both professionally and personally. Resignations, retirements, budget shortfalls, economy problems, Expo success, TROE Center progress, war and weather all have played a role in where we are today, both professionally and personally.

The war with Iraq has held headlines for the past couple of months as that regime was brought down. The economy continues to reek havoc on retirement plans and revenues for all levels of government. A dry spring follows a cold, dry winter making a reliable irrigation system a necessity rather than a luxury. Then it starts to rain, doesn't know how to quit and remains cool. Again, as always, we're reminded that "average" weather is many times made up of extremes.

In no particular order, a number of things follow that have had a direct impact on the MTGF and its Allied Associations. As most are aware, Dr. Jon Powell resigned last summer as the Turf Pathologist at the University. Given anticipated budget shortfalls, it appears that this position will not be filled any time soon. Discussions continue in an attempt to find a way that might allow for continued funding for this position. Several concerned parties have been meeting with Dean Muscoplat and others in an attempt to find a workable solution so that this position can be filled.

In addition, Dr. Don White has begun his phased-in retirement after forty plus years of service to the University and the Green Industries throughout this area. We all certainly wish Don the best and thank him for all of his many contributions over the years. As of this writing, three candidates have been interviewed for this position and the Search Committee has forwarded their recommendation to the appropriate parties. Negotiations are in progress with the chosen candidate and the MTGF has indicated its support should that be a necessity as the negotiation process proceeds. It appears as of now that the Dean will go forward with filling this position. This is very encouraging given the budget shortfall that the University is experiencing.

Filling the Department Head position in Horticultural Science also seems probable as four candidates have been interviewed and a recommendation has been forwarded. One of many difficulties compounding funding for these and other positions within the University is that very few

retirements are materializing due to the economy's impact on the retirement funds of everyone over the past couple of years. This eliminates the possibility of making up shortfalls through attrition and the transfer of available funds from one area to another. Fortunately Dean Muscoplat views Horticulture in general, and turf in particular, as high priorities. Consequently these positions have been moved to the top of the list of priorities. This imparts a degree of optimism for the Green Industries in an otherwise very gloomy budget situation at the University of Minnesota.

During the past year the TROE Center has begun to take shape. A number of things took place in order for this to happen. First, Dr. Brian Horgan came on board and gained well-deserved support from both the University and the turf industry. Second, the University committed an additional sixteen acres of land on the St. Paul Campus for use by the Turfgrass Working Group. As a direct result of these two things, industry, spearheaded primarily by Paul Eckholm and others within MGCSA, including a number of generous vendors, donated funds and in-kind items that facilitated the construction of a putting green, including earth moving, root zone materials, drainage, irrigation and seed. Additional research projects have since been either initiated or contracted for on this land to further advance the purpose of this site. Joining the MGCSA, the MTGF and the MSTMA have made donations to further support the activities within the turf and grounds programs at the TROE Center.

As noted elsewhere in this publication, the first Minnesota Green Expo, held in January of this year was a huge success. The financial model that was developed prior to the 2003 Minnesota Green Expo was exceeded. As a result, plans are well underway to build on this initial success when the next Expo is held in January 2004.

The annual U. of M. Field Day will be held on the St. Paul Campus on July 24, 2003. Please plan to attend so you can see all of the progress that has been made in the areas of turf and grounds research. Specific topics and presenters are included in this issue.

Two pesticide Recertification Workshops were successfully sponsored by the MTGF last fall. Based on that success, plans are in place to again sponsor a workshop in the Metro area and another in an out-state location. More information on dates and locations are provided elsewhere in this publication.

All-in-all the past twelve months have been eventful. The MTGF is financially sound and is positioned to continue with its mission. As in all organizations, individual and association involvement is critical to success. The efforts of a few are providing benefits for all. Given all of the uncertainties around us today, this would be a good time to ask ourselves "What have I done lately to better my association and my profession?" From where I sit, I can assure you that there are a few that are doing a lot. Why not join them? There is room on the team that is doing the pulling! ■

Al Stabenow Leaves The Catholic Cemeteries

Dave Kemp, MTGF Board Member

After thirty-two years of service to The Catholic Cemeteries of the Archdiocese of Saint Paul and Minneapolis, Al Stabenow resigned from his position as Operations Manager as of April 30, 2003.

In 1971 Al started out as a field employee at Calvary Cemetery in St. Paul and was later appointed Superintendent of that cemetery. After managing Calvary Cemetery he was appointed Superintendent of St. Mary's Cemetery in Minneapolis and Gethsemane Cemetery in New Hope. In the mid-1990's he teamed up with Jon Louris and Dave Kemp to become the Operations Management Team whose primary responsibility was to manage field operations of all cemeteries.

Al will be moving south to Lake Crystal, MN in order to be closer to his son, daughter, their spouses, and Al's two new grandchildren. He has already purchased a new home in Lake Crystal and looks forward to a future with his family.

Al's pleasant manner, sense of quiet confidence, and collaborative abilities to work in a positive manner with everyone at The Catholic Cemeteries will be greatly missed. A farewell reception and open house for Al was held on April 29, 2003 at the new Resurrection Cemetery office.

Editor's Note: Al has resigned from the MTGF Board of Directors after serving for several years. His regular attendance at meetings, thoughtful input and pleasant demeanor will be missed and we thank him for his years of service.



S&S TREE AND HORTICULTURAL SPECIALISTS

"Nobody Knows Trees And Turf Better"



Turf Care Services
 - Aeration – Seeding
 - Topdressing – Consultation
 - Tom Rudberg
 Certified Sports Field Manager



Tree Care Services
 - Pruning—Removal
 - Insect & Disease Control
 - Oak & Elm Disease Control
 - 24 Hr. Storm Service

Call 651-451-8907 or visit us at www.s-stree.com

Help Accomplish Our Mission Last issue via "Snail Mail"?

The stated mission of the Minnesota Turf & Grounds Foundation is "to promote the green industries in Minnesota through support of research, education and outreach at the University of Minnesota and elsewhere". Volunteers who make up the current Board of Directors of the MTGF, like those before them, are committed to accomplishing this mission in every way possible that does not inconvenience members or increase their costs unreasonably.

The more revenues increase &/or expenses decrease, the more the MTGF has at its disposal to support its mission. While revenues are increasing, so too are expenses. At the last meeting of the Board of Directors a resolution was passed to make this publication available electronically to all members except those who opted to continue receiving a hard copy via "snail mail". It is anticipated that this will result in savings of several thousand dollars annually.

The resulting cost savings could then be allocated toward furthering the stated mission of the MTGF. **Consequently, this is the last issue of *Clippings* that will be mailed to you unless you indicate to our office that you wish to continue receiving a hard copy in the regular mail as you have in the past.**

Clippings will now be available on our web site, www.mtgf.org as soon as the file is made available from the printer. You can also request that it be e-mailed to you if you provide us with a current e-mail address.

COMMITTED TO THE TURF AND
 GROUNDS INDUSTRY





BROOKLYN CENTER, MN
 763-592-5600
 800-362-3665

FARGO, ND
 701-281-0775
 800-782-1031

TORO

Count on it.

WWW.MTIDISTRIBUTING.COM

MTI DISTRIBUTING

Lots of Winners at Casino Expo Party

Thanks to all the companies who donated a prize and thanks to everyone who participated in the Minnesota Green Expo Casino Party. Bailey Nurseries Inc. and Hedberg Aggregates deserve special thanks for being the sponsors of the event and thanks also to co-sponsor Bachman's Nursery Wholesale Center.

Prize

- Snapper Snow Blower
- Embroidered Jacket
- Embroidered Jacket
- Ruttger's Lodge Certificate
- Ruttger's Lodge Certificate
- Sears Gift Card
- Sears Gift Card
- Best Buy Gift Card
- Timberwolves Tickets
- Galyan's Gift Certificate
- Echo Power Blower
- Deer Repellent
- Deer Repellent
- Fuel Card
- Stihl PL30 Lopper
- Head Covers & Gift Card
- Plant Material
- Timberwolves Tickets
- Hilton Stay & Dinner
- Hilton Stay & Dinner

Donated By

- Sun Turf**
- Team Time**
- Team Time**
- Plaisted Companies**
- Plaisted Companies**
- Cross Nurseries**
- Cross Nurseries**
- Monrovia Growers**
- S & S Tree & Hort.**
- Simplot Partners**
- Charlestown Power**
- Liquid Fence**
- Liquid Fence**
- Super America**
- Nieber Implement**
- Cycle Works of MN**
- Sawyer Nursery**
- MN Timberwolves**
- Minneapolis Hilton**
- Minneapolis Hilton**

Prize Winner

- Eric Lilga, Boulder Images
- Rob Simon, Water Wizard
- Gregg Funfar, Funfar Landscaping
- Tom Albers, Borgert Products
- Dave Sundmark, City of St. Paul
- Louis Bourgeois, Oasis Distinctive Landscaping
- Mike Simons, Interlock Concrete Products
- Jerry Bitzan, ISD 206
- Brad War, Klaus Nursery
- Paul Hacker, Stoney Creek Landscape
- Deb Roetger, Great River Gardens
- Rick Lucia, North Lights Landscape
- Polly Stevens, Dundee Nursery
- Lucian Greeninger, Golden Eagle GC
- Jeff Davis, Permagreen
- Don Grove, Hydrologic
- Adam Zopfi, Midwest Landscapes
- Brenda Chaney, Landsburg Nursery
- Susan Johnson, Que's Landscaping
- Bob Reihe, Premier Irrigation

Congratulations to all winners and thanks to all prize donors!



Great networking and fun for all offered at the packed Casino Party.

HEDBERG
LANDSCAPE SUPPLIES
"Built on Service"

We offer free Anchor product installation training

FOR ALL OF YOUR LANDSCAPE HARDGOODS

- Concrete Retaining Walls
- Natural Stone
- Decorative Rock
- Poly
- Gravel
- Mulch
- Concrete Pavers
- Manufactured Stone
- Water Garden Supplies
- Black Dirt
- Sand

Large in stock selection & same day delivery

3 CONVENIENT LOCATIONS

PLYMOUTH 763-545-4400	ROSEMOUNT 651-423-5048	STILLWATER 651-748-3158
---------------------------------	----------------------------------	-----------------------------------

www.hedberggregates.com

YOUR SOURCE FOR:



Anchor
RETAINING WALL SYSTEMS



ANCHOR
PAVING STONES

STOP
SLIPPERY
FLOORS & STEPS

call
763 571-1769
www.surestop.com

Sure Stop Floor Safety
"your solution to any slippery floors"



INDUSTRY EXPERTS

TAKE A TEST DRIVE.

For years North American Green's erosion control blankets and turf reinforcement mats have been successfully used to stabilize critical slopes and channels along our highways.

But you know what they say about all work and no play.

Our products are also a natural fit for outdoor recreation projects. From tee to rough, from the fairway to the green, our biodegradable blankets protect your valuable seed and topsoil, helping to assure a healthy stand of vegetation.

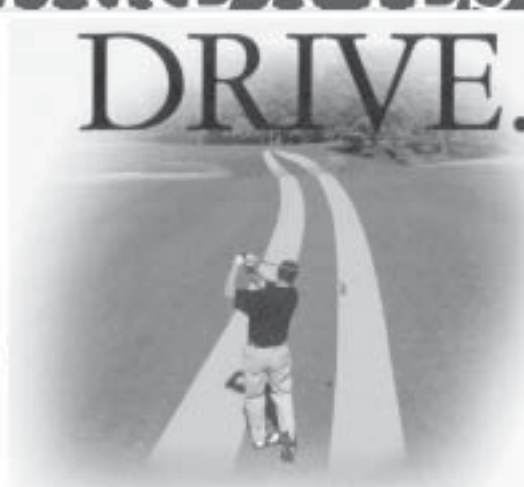

For a strong stand of vegetation – a mat that won't get caught in your mower blades – North American Green's full line of temporary and permanent erosion control products are your ace in the hole.

Come to www.nagreen.com and discover our environmentally friendly approach to helping grass grow where people play.

For more information contact your North American Green Distributor listed below.

From Highways to Fairways



BROCK WHITE
COMPANY
 CONSTRUCTION MATERIALS

2575 Kasota Avenue
 St. Paul, MN 55108
 651-647-0950, Fax 651-647-0403
 1-800-880-3210
www.brockwhite.com

ST. PAUL EAGAN ELK RIVER ST. CLOUD ROCHESTER DULUTH FARGO BISMARCK

PHOSPHORUS FERTILIZER TRAINING PROGRAM FOR GOLF COURSE PERSONNEL

July 24, 2003 St. Paul Campus 1:00 P.M. – 5:00 P.M.

*By: Dr. Brian Horgan,
Turfgrass Extension Specialist*

Last year the State of Minnesota passed a law that restricts the use of phosphorus fertilizer applied to turf with some exceptions. The first exception is when you have a soil test to prove the need for additional phosphorus. The second is a one year exception if you are establishing or renovating turf. The third exception is for golf course personnel who have participated in an ongoing training program approved by the Minnesota Department of Agriculture.

The Turfgrass Science Program at the University of Minnesota has received approval from the Department of Agriculture for a phosphorus training program. This 4 hour program will be offered in the afternoon following the Turf and Grounds Field Day, July 24th on the St. Paul Campus. The program will start at 1:00 p.m. immediately following the conclusion of the Field Day and end by 5:00 p.m. The cost of the program is \$75.00 and includes a notebook full of resources and references relating to phosphorus applications.

To date, 200 golf course personnel have received training. This will be our third opportunity this year with a fourth yet to be determined. Don't wait. Take advantage of this opportunity. You will receive a registration in the mail by the end of June or you can use the registration below to reserve your spot. You can find more information about this training program on the website www.turf.umn.edu. If you have additional questions, please call Dr. Brian Horgan at 612-624-0782.

There will be a wealth of information made available on the St. Paul Campus July 24th at the University of Minnesota. If you plan to take advantage of this training program, why not come earlier for the Annual U. of M. Field Day starting at 7:45 a.m. All of the experts listed in the Field Day article elsewhere in this issue will be available in the morning to answer any questions you might have in addition to sharing information on a variety of topics.

UNIVERSITY OF MINNESOTA
PHOSPHORUS FERTILIZER TRAINING PROGRAM
FOR GOLF COURSE PERSONNEL
JULY 24, 2003, 1:00 – 5:00 P.M.
PRE-REGISTRATION FORM

Name: _____

Affiliation: _____

City: _____ State: _____ Zip Code: _____

Phone: _____ E-mail: _____

Pre-Registration Phosphorus Training Program, per person \$75.00

Make checks payable and return to: MTGF
University of Minnesota
422 Alderman Hall
1970 Folwell Avenue
St. Paul, MN 55108

PESTICIDE RECERTIFICATION WORKSHOPS

The Minnesota Turf & Grounds Foundation has again been granted the opportunity to sponsor two Pesticide Recertification Workshops this year. Last year's events provided a valuable service to the members of our Allied Associations which resulted in revenue generation that is being used to support our mission of supporting research, teaching and outreach at the University of Minnesota.

Your participation in one of these events not only provides you with a venue at which to recertify, but it provides you with a very good day of networking with your peers. The MTGF is again planning to locate one within the metro area as well as one in an out-state location.

The metro event will be held at Golden Valley Country Club on October 16th. The date and location of the out-state event is yet to be determined, but will most likely be in the central part of the state as it was last year. While 2003 is considered a "down year" for the number of applicators needing to recertify, it is hoped that MTGF members needing to recertify this year will choose one of these venues to satisfy their requirement. A separate mailing will be made to all MTGF members well in advance of the scheduled dates so that they can reserve a spot at the

location of their choice. A great slate of speakers will be present to make what is a mandatory program both informative and enjoyable.

Your participation not only satisfies a requirement for you but it also is another way that you can support your industry. All profits from these events goes directly into the pool of funds that the MTGF has available to support industry activities at the University of Minnesota. If you need to recertify this year, please consider choosing one of these venues to complete your requirement. Exciting things are happening within the turf and grounds arenas at the University and the MTGF feels very strongly about maximizing the support it can provide in these endeavors.

THANK YOU SPONSORS

Thank you to the following companies for their generous support of the 2003 Minnesota Green Expo:

PLATINUM SPONSORS

Bailey Nurseries
Hedberg Aggregates

GOLD SPONSORS

Bork Tree Farms
AgStar Financial Services, ACA
Bachman's
Cherokee Manufacturing
Gertens

BRONZE SPONSORS

Aggregates Industries
Anchor Block Co.
Central Landscape Supply
Central Turf Farms
Cross Nurseries
Farber Bag & Supply Co.
Hoffman & McNamara
Innovative Landscape Supply
Irrigation by Design
Law's Nursery
MplsSt.Paul Magazine
Shemin Nurseries
Terra Products
Walters Gardens

**"Our Field is
Preparing Your
Field"**



Kromer Co. LLC
1-800-373-0337
www.kromerco.com

MSTMA News

Jeff Hintz

I am Jeff Hintz, President of the Minnesota Chapter of the Sports Turf Manager's Association (MSTMA). I transitioned from President-Elect to President during the annual MSTMA meeting held during the Green Expo in January, 2003. I am excited to work with the talented group of board members our organization has: Greg Hoag—President-Elect, Randy Bastyr—Treasurer, Greg Brodd—Secretary, Paul Griffin—MTGF Representative, Don Belkengren—Commercial Representative and Mike McDonald—Past-President. We are committed to planning a year that will be beneficial for you if you are willing to take the time to participate in the scheduled events. We spend a considerable amount of time planning and would welcome you to submit your comments and any suggestions to the "Feedback Page" on our local website (www.mstma.com).

The purpose of the Minnesota Sports Turf Managers Association (MSTMA) is:

- To encourage the collection and dissemination of scientific, educational and applied knowledge through association with those persons engaged in, and who are concerned with, the construction, maintenance and use of sports turf areas for high quality and safe playing conditions.
- To provide educational grants that promote the sports turf industry.
- To support research and development of superior playing surfaces for sports turf facilities.
- To promote the development, design and use of related materials and equipment for the sports turf industry.
- To promote and assist the national governing body of the Sports Turf Managers Association to fulfill its mission, goals and objectives

The Objectives and goals of MSTMA is:

- Provide members with current information on field maintenance.
- Support educational and hands-on how-to-do workshops.
- Ability to network with other sports turf managers for problem solution.

The agenda we have developed is:

2003:

Spring Workshop – Tuesday, April 8th in the HHH Metrodome

Chapter Clash with Iowa Chapter – July 11 & 12 in Minnesota

Tour on Wheels – Wed., August 13th incorporating a St. Paul Saints game

Fall Workshop – Thursday, October 16th

2004:

Spring Workshop – Week of March 22, 2004

Chapter Clash – July 9-10, 2004

Tour on Wheels – Based on game schedule

Fall Workshop – October 14, 2004

Take time to visit our local website at www.mstma.com. The goal of the website is to provide current and accurate information that is available at all times. You will find membership information and forms, registration forms, schedule of events, clothing order form, community service project information, feedback form, etc.

Have a safe and productive 2003 season. I hope to see you at many of the MSTMA sponsored events throughout the year.

PRESIDENT'S REPORT

*Greg Hubbard
MTGF President*

As Spring has sprung, visions of our inaugural Green Expo last January are melting away. Our conference was warmly received by all and with your valued input in mind, we are well on the way towards an improved and more stimulating conference for 2004. Thanks go to our conference committee and Chair James Bade, to the MNLA and Executive Director Bob Fitch, and to our own Executive Director Larry Vetter for their fine performance. Somehow, they'll top the excitement and creativity of our last conference. Look for a bigger trade show, enhanced education, and more camaraderie!

Though we experienced rain last year, the outlook for the 2003 University of Minnesota Field Day is bright and sunny! I expect that the Turfgrass Working Group and Dr. Brian Horgan will have plenty of new ideas and information to share with us. Make sure to look for registration forms soon either by mail or via the internet at www.mtgf.org. I'm sure the word has spread about last year's outstanding event and interest will be outstanding.

The University, like many public institutions, is now in the throes of devastating budget cuts and has asked for our support. Their proposal asks the MTGF to help provide financial support to the new professors being added to the turf program. Contract negotiations are currently underway for a replacement for Dr. Don White and a new turf pathologist is possibly in the works as soon as September, 2004.

In return for our help, we are asking the U to commit to our TROE Center in a meaningful fashion to get this project underway after the budget crisis subsides. We have supported similar efforts in the past and expect to consider their request at our next Board of Directors Meeting on June 11, 2003. We expected to be further down the road with the TROE Center project by now, but at least some progress is being made towards its development. Let your Board Members know what you think about our University relationships!

In the future, expect to receive your "Clippings" via internet. As technology makes information transfer easier, we feel that we must join the effort. Please make your e-mail addresses available to your allied association so we can update our mailing lists.

Have a great summer and see you at Field Day!



Over 45 Years of Quality Sod

...for sunny and shady locations

- Elite Compact Kentucky Bluegrass
- Fine Fescue/Kentucky Bluegrass Mix
- Creeping Bentgrass
L-93, Putter, and Pennncross
- Salt Tolerant Turf
- Tuff Turf (Erosion Control)

**Peat, Mineral, and Washed Forms
Big Rolls (42" and 30") and Small Rolls**

*Call for pricing and availability
(651) 674-7937*

REGIONAL TURFGRASS RESEARCH CONFERENCE

Brian Horgan

Each year, turfgrass faculty from twelve universities gather to discuss current research, develop regional projects and provide a report on the "Current State" of the turf industry within their respective states. This year the University of Minnesota is fortunate to be hosting this conference. This two-day event will be held at the University of Minnesota Landscape Arboretum located in Chanhassen, MN. The dates of the conference are June 17 and 18. In addition to the structured meeting, a half-day tour of the TROE Center will occur on the 17th.

The Universities represented include the following: Michigan State, Ohio State, Purdue, Illinois, Wisconsin, Southern Illinois, Minnesota, Missouri, Kansas State, Nebraska, North Dakota and South Dakota.

I would like to thank the MTGF for their support of this conference. To reduce costs for the conference, the MTGF Board of Directors voted to pay for dinner on the 17th. I appreciate the MTGF's continued support of the University of Minnesota and for helping with this regional conference.

The King of Diamonds.



Red Ball Diamond Aggregate

Playing great ball means putting the best line-up on the field. Building a great ball diamond means building it with the best playing surface in the nation, Red Ball Diamond Aggregate from Bryan Rock Products, Inc.

RBDA has a number of all-star qualities that make it the best ball diamond surface in the league:

- The 100 percent crushed red dolomitic limestone (RBDA) is especially designed to allow water to drain, preventing costly and inconvenient rain-outs for games and practices. There is no need to add expensive drying agents.
- RBDA is a durable, permanent and indestructible aggregate which is easy to maintain.
- Properly installed it will last decades.
- Because of its red color, it actually absorbs light, reducing glare so the players and fans will see the ball clearly.

Bryan Rock Products, Inc. is the King of Diamonds. They have supplied RBDA to thousands of ball diamonds nationwide for over 25 years. Let your players really excel, call Bryan Rock Products, Inc. today and let them supply you with an all-star ball diamond.

Bryan Rock Products, Inc.

Phone: (952) 445-3900 Toll Free: (800) 382-3756 Fax: (952) 445-0809
www.bryanrock.com

FERTIMIX, INC.

Wholesale Manufacturer and Distributor of:

**Professional Turf Fertilizer Blends
Crabgrass and Broadleaf Control Fertilizers
Lebanon Turf Products
Nature Safe Organic Fertilizers
Complete Line of Herbicides, Fungicides, Wetting Agents
Melt-Mor Deicer**

We manufacture the fertilizer at our plant in Jordan, MN and can formulate the analysis to fit your needs in regular and mini-sizing. We offer several sources of slow release nitrogen and can add micro-nutrients as needed. Forklift delivery is available throughout the metro area. Call today for a free quote.

Our professional turf representative is:
Paul Jones
Tee Shot Marketing, Inc.
(Cell) 612-860-5464 or 952-881-2256

Fertimix, Inc.
Norma Bendzick
512 North Broadway Jordan, MN 55352
800-333-8608 or 952-492-3377



Greetings & Happy Spring to All

*Dale J. Bachmeier, President
MN Association of Cemeteries*

On behalf of the MN Association of Cemeteries greetings and a happy spring to all. We are a group of private and public cemetery operators as well as suppliers who serve our industry. We seek to provide information to our members about new technology, new legislation and changes within the industry. We also interconnect with religious communities, municipalities and related industries throughout the state.

Cemeteries are a gathering place for people to mourn and remember as well as celebrate the lives of our loved ones who have died. We take our charge very seriously to care for the grounds where those people are buried. The biggest challenge for us as grounds keepers in to maintain a beautifully groomed environment even though we are constantly changing the grounds as we dig graves. It presents interesting challenges indeed.

Our organization also exists to provide information to the public. Our website is: www.mncemeteries.org. Please feel free to visit the site and contact any of our members for information.

Editor: Larry G. Vetter
MTGF Office

University of Minnesota
422 Alderman Hall
1970 Folwell Avenue
St. Paul, MN 55108-6007
Phone: (612) 625-9234
Fax: (612) 624-4941
E-mail: vette008@tc.umn.edu
Website: www.mtgf.org



University of Minnesota
 422 Alderman Hall
 1970 Folwell Ave.
 St. Paul, MN 55108

Change Service Requested

Prsrt Std
 U.S. Postage
PAID
 Minneapolis, MN
 Permit No. 155

What's New?
covermaster.com
 The web's most comprehensive site of protective sports surface covers.

Baseball infield covers come in standard and custom sizes

Full size covers for football and soccer are readily available

Ultimate Field Cover Protection

Manufactured in North America, COVERMASTER® covers are made from the widest available materials to limit the number of seams and can be custom designed to your requirements. We also offer the widest range of colors in the industry.

With more than three decades of experience and our commitment to achieve complete customer satisfaction, COVERMASTER® field covers are recommended by more groundskeepers than any other.

Ultimate Field Cover Handling

The **TARP MACHINE™** (left photo). Attached to any 14 HP tractor equipped with a PTO, it rolls the cover on and off the field in a minimum of time.

The **TARPMATE™** (right photo) stores any size cover. Strong and lightweight, the 26" diameter plastic roller is complete with safety end caps and is available in three standard lengths.

FREE VIDEO

WHAT OTHERS SAY...

Very good... highly recommended...
 Dunham Wright, Facilities Supervisor,
 Northeast Louisiana Univ., Monroe, LA

Experience with Covermaster has been outstanding... appreciate special attention...
 Ray Tanner, Head Baseball Coach,
 Univ. of South Carolina, Columbia, SC

Excellent quality with competitive prices...
 Johnson Bowie, Associate AD,
 Drexel University, Philadelphia, PA

Delivered in perfect condition... best product I looked at...
 John Milano, Supt. of Parks,
 City of Middletown, Middletown, CT

From 1-18, your company is a 10...
 Jim Simmons, Facility Mgr.,
 Buckingham Little League, Ft. Myers, FL

Great service... the best...
 Chip Baker, Asst. Baseball Coach
 Florida State University Tallahassee, FL

Covermaster takes extra step to meet customer's exact needs...
 Gary Mayes, Asst. Gen. Mgr.,
 Wisconsin Timber Rattlers, Appleton, WI

Response time was great... recommended by groundskeeper of St. Louis Cardinals...
 David Hopkins, Alton American Legion
 Baseball, Alton, IL

COVERMASTER™
COVERMASTER
COVERMASTER
MASTERS IN THE ART OF SPORTS SURFACE COVERS

CALL TOLL FREE
1-800-387-5808

www.covermaster.com
E-MAIL: info@covermaster.com

COVERMASTER INC., 100 WESTMORE DR. 11-D, REXDALE, ON, M9V 5C3 TEL 416-745-1811 FAX 416-742-6837

MEMBER

MANAGEMENT ASSOCIATION